

**MACK**<sup>®</sup>

# Maximise your payload.



## **MACK TRIDENT**

The Mack Trident range is built with versatility in mind, proving itself in the heavy construction and line-haul applications. The Trident with axle forward configuration is perfect for extreme axle measurements to maximise payload. The Mack Trident Axle Forward will make light work of navigating a tipper and dog on any worksite.

Max GVWR

**27.6**

TONNE

Power

**535**

MAX HP

Peak Torque

**1,920**

LBS.-FT. MAX

**TRIDENT**

## Key Features

The front axle position offers optimum payload making it perfect for tipper and dog applications

Powered by the Mack MP8 eSCR engine delivering up to 535hp and 1920lb.ft. (2600Nm) torque

*mDRIVE*™ automated manual transmission with deep reduction gears, takes all the effort out of gear changes and provides flexibility in low speed applications

Introducing dual voltage system, 12V cab and chassis with 24V engine and transmission

Mack Infotainment system, compatible with Apple CarPlay, Android Auto compatibility and wireless phone charging pocket

“Road Stability Advantage” rollover prevention

Quiet and comfortable cab with new cab suspension for an improved ride

Great fuel economy and low emissions

Built in Australia for Australian conditions



## Comfortable Interiors

The Mack Trident comes with new levels of driver comfort and functionality, to keep drivers comfortable and safe all day. Tilt/telescoping steering column, air suspension driver seat and all controls within reach keep drivers in control.

## Total Support

Mack Genuine Parts are as tough as your truck. With premium materials and precision engineering, they're built to take whatever the road can throw at them. Mack Total Support gives you the added confidence of warranties, servicing and maintenance from the people who made your machine. With Australia's largest dealer network, you can take advantage of the peace of mind that comes with a Mack service plan tailored to your business.

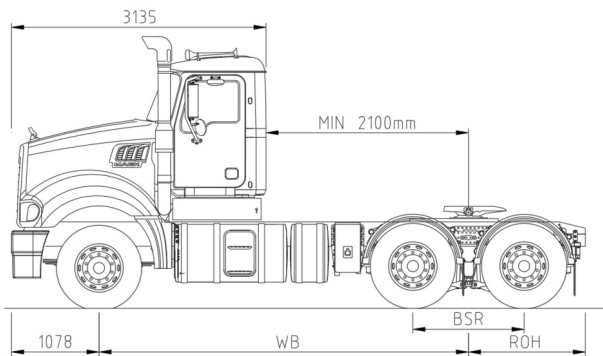

**6x4 Day Cab Tractor**

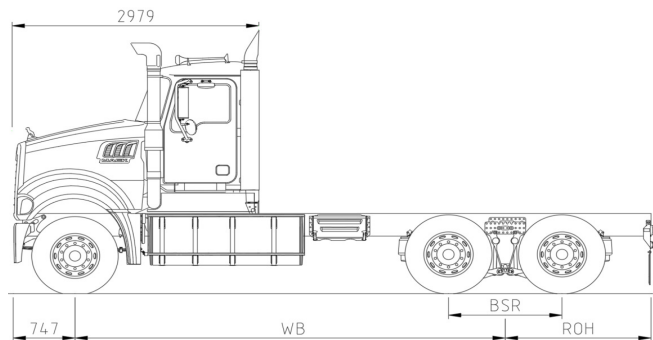

**6x4 Day Cab Rigid**

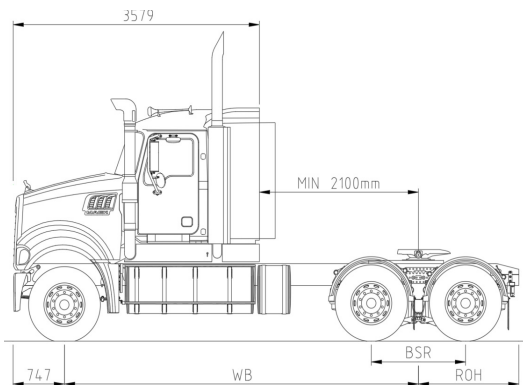

**6x4 28" Super Cab (710mm)**

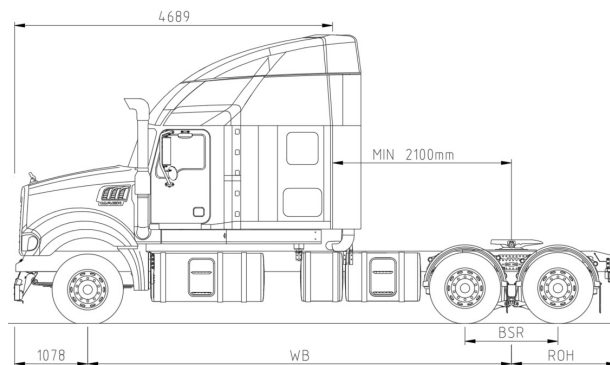

**6x4 36" Stand-Up Sleeper (914mm)**

<b>Configuration*</b>	6x4			
<b>GCM</b>	Please speak with your Mack Dealer for GCM ratings specific to your chosen spec.			
<b>Cab Type</b>	Day Cab Tractor	Day Cab Rigid	28" Super Cab	36" Sleeper
<b>Wheelbase</b> (mm.)	4,720, 4,745 4,770, 4,795 4,970, 4,995 5,120, 5,145 5,420, 5,445 5,770, 5,795	5,445, 5,795	5,145	5,270, 5,295
<b>Maximum Fuel Capacity**</b> L	850	970	1,005	1,540
<b>AdBlue Tank Capacity**</b> L	95 125	125	125	150 200

\*Other configuration options available via C.A.

\*\*Various fuel packages available.

<b>ENGINE</b>	Mack MP8 13 litre, 500hp & 535hp eSCR Emission Level Euro6 (ADR80-04)		
	500hp (373kW) / 1840lb.ft (2490Nm)		
	535hp (399kW) / 1920lb.ft (2600Nm)		
<b>Engine Brake</b>	Advanced PowerLeash engine brake Engine retarding power up to 495hp (370kW)		
<b>Exhaust</b>	Single RHS frame mounted catalyst with stainless steel heat shield		
	Outlet twin 152mm (6") vertical exhaust		
	Exhaust tip height above ground 3.5m		
	RHS low underframe exhaust outlet		
<b>Air Intake &amp; Filter</b>	Donaldson 279mm (11") single dry type element, dual canisters mounted under cab		
	Steel dust extractors and external raised air intakes mounted in front of the cabin 'A' pillars		
<b>TRANSMISSION</b>	<b>STANDARD</b>	<b>OPTION</b>	<b>OPTION</b>
<b>Transmission Type</b>	AMT <i>m</i> DRIVE 12-speed	AMT <i>m</i> DRIVE HD 13-speed	AMT <i>m</i> DRIVE XHD 14-speed
<b>Multispeed Reverse Gears</b>	4	6	6
<b>LO / HI</b>	14.94 / 1.00	17.54 / 1.00	32.04 / 1.00
<b>FRONT AXLE</b>	Mack FXL 14.6 Single Steer		
<b>Capacity</b>	14,600 lbs (6.6t)		
<b>Suspension</b>	Front Parabolic Spring		
<b>CHASSIS FRAME</b>	<b>STANDARD</b>	<b>OPTION</b>	
<b>Rail Dimensions</b>	300 x 90 x 8mm	300 x 90 x 9.5mm	

<b>REAR AXLE</b>	<b>STANDARD</b>	<b>OPTION</b>
<b>Axle Type</b>	Meritor RT46-160GP	Mack 2370B
<b>Capacity</b>	46,000 lbs (21t)	50,000 lbs (23t)
<b>Suspension</b>	Mack AL460 Air Suspension	
	Mack AP460 Air Suspension	
	Mack Air Ride Suspension	
<b>CAB</b>	Fusion Cab, ECE29 (cab strength test) compliant	
<b>Cab Storage</b>	Overhead storage available	
	Rear Wall storage available	
	Door Storage (2 pockets)	
	Centre storage console available	
<b>Cab Type</b>	Day Cab	
	Super Cab - 710mm Rear Cabin Extension (28")	
	Sleeper - 914mm Stand-Up Mid-Rise (36")	
<b>BRAKE SYSTEM</b>	Bendix Antilock Braking System	
<b>Front Brakes</b>	Front 'S' Cam with Iron Brake Drum	
	Front Disc Brake	
<b>Rear Brakes</b>	Rear 'S' Cam with Iron Brake Drum	
	Rear Disc Brake	
	ABS	
	Grade Gripper - Hill Start Assist	
	Mack Road Stability Advantage (ESP - Electronic Stability Program)	

■ Shaded areas indicate optional specifications.

<b>SAFETY</b>	Advanced active safety technology
<b>Alerts</b>	Alert Prioritisation
	Bendix Blindspotter
	Following Distance Alert
	Impact Alert
	Lane Departure Warning
<b>Braking Intervention</b>	Stationary Object Alert
	Stationary Vehicle Braking
	Enhanced Collision Mitigation
	Adaptive Cruise Control With Braking
	Multi-Lane Automated Emergency Braking
<b>FUEL TANKS</b>	Highway Departure Braking
	Various fuel packaging options available
<b>LHS</b>	350L, 400L, 500L & 585L Round tanks
	360L & 700L 'D'-Shape tanks
<b>RHS</b>	350L, 385L & 420L Round tanks
	480L 'D'-Shape tank

<b>ADBLUE TANKS</b>	DEF TANKS
<b>LHS Outside of Frame</b>	95L & 125L Round tanks and 150L 'D'-Shape tanks
<b>WHEELS</b>	10 Stud Options
<b>285mm PCD</b>	8¼" steel disc
	8¼" machine buff disc
	8¼" and 9" polished alloy disc
	8¼" and 9" polished Dura-Bright alloy disc
<b>335mm PCD</b>	8¼" steel disc
	8¼" and 9" polished alloy disc
	8¼" and 9" polished Dura-Bright alloy disc
<b>TYRES</b>	Bridgestone / Michelin tyres
<b>PAINT</b>	Cab/sleeper: Single non-metallic cab colour (Incredible White standard)
	Chassis: Single non-metallic chassis colour (Black standard)
<b>ACCESSORIES</b>	Many factory fitted accessories which are not listed are also available
	All customers are encouraged to see their Authorised Dealer for full details

☐ Shaded areas indicate optional specifications.



**MACK®**

All illustrations, specifications and descriptions in this specification are based on the latest product information available at the time of this publication. The right is reserved to make changes in price, materials, equipment, design, specifications, diagrams and models, and to discontinue models of equipment at any time, without notice and without incurring any obligation whatsoever. For more information on additional options and accessories, contact Mack Trucks Australia. ([www.macktrucks.com.au](http://www.macktrucks.com.au)).

©2024 Mack Trucks, Inc. All rights reserved. Mack, Mack and the Bulldog design, Bulldog and all other marks contained herein are registered trademarks of Mack Trucks, Inc. and/or Mack Trucks, Inc. affiliated companies. All other marks contained herein are the property of their respective owners.

SS-MTA-CMH-090524

